



**Nuova Rade**

Marine - Plastics Technology Experts

# Installation, Operation & Repair Manual



## Waste Pump With Macerator (94562 - 94563)

Waste pump with macerator is designed to empty marine holding tanks of normal waste. It is also an excellent choice for emptying fish boxes of scales and residual waste. A flow rate of up to 12 gallons per minute conveniently empties any tank in minutes.

The unique four-blade design ensures waste is ground up thoroughly. The pump is self-priming to a five foot lift when impeller is wet, four foot lift when impeller is dry, but for optimum performance and life it should be mounted as close to the tank as possible.

Marine pump out must be in proper discharge zones only. This macerator will not handle hard objects, rags or feminine napkins.

### Product Specifications

**Motor:** Seamless can motor. Thermally protected.

**Lead wires:** 14GA

**Fuse:** 20AMP

**Pump Type:** Flexible Impeller

**Duty Cycle:** Intermittent duty only

**Ports:** Inlet: 1 – 1/2” hose barb & 1 – 1/2” NPT male

**Outlet:** 1” hose barb

**Impeller:** Rubber and zinc alloy

**Blade:** 316 stainless “Four-Blade”

**Dimensions:** See drawing

**Weight:** 2.35kg

**Approvals:** CE

**Typical Flow:** Dependent on fluid viscosity (Chart below based on zero meter suction lift of water).

Model	Voltage	Head (m)	Flow (gpm/lpm)	Max draw (A)
94562	12	3	12/45	12
94563	24	3	12/45	6

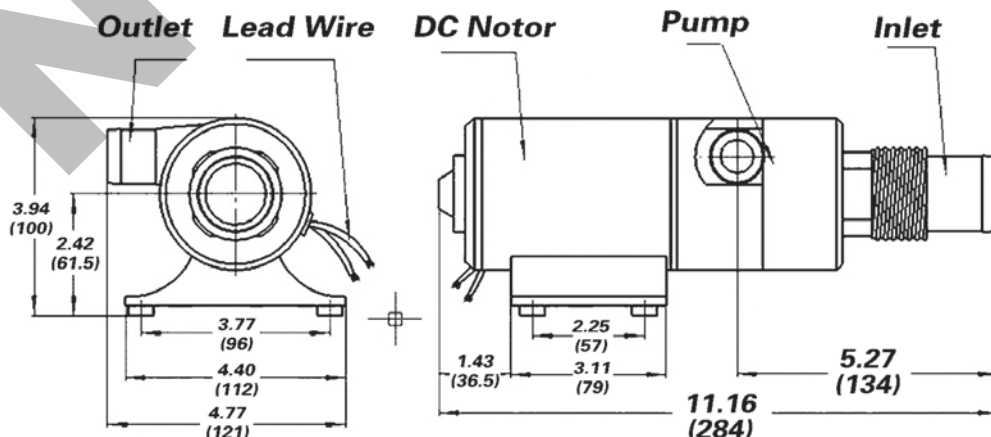



**Nuova Rade**

Marine - Plastics Technology Experts

## Waste Pump With Macerator (94562 - 94563)

### Electrical & Plumbing Connections

#### Electrical Connections

**WARNING:** If the pump is operated in an area containing flammable vapors, the wire leads must be joined by insulated mechanical locking connectors. Loose or inadequate wire connections can spark, resulting in an explosion resulting in property damage, injury, or death. **All electrical installations should be done by a qualified electrician.**

- Pump should be operated on a separate circuit.
- Pump should be connected to properly sized momentary switch. This prevents pump from damage due to long periods of dry run condition.
- Separate circuit from power source
- Proper size momentary switch mounted near pump
- Proper fuse size and type
- Insulated wire connectors

12 Volt System Total Wire Length* Feet [m]	Min. Wire Size (20 Amps)	
	3% Drop GA	10% Drop GA
1-10 [.3-3]	#10	#16
11-20 [3.3-6]	#8	#14
21-30 [6.4-9.1]	#6	#12
31-60 [9.1-18.2]	#4	#10

\* Length from power source to motor and back to ground.

#### Plumbing Connections

Pump should be mounted as near as possible to tank to minimize dry run.

**INLET:** Always install pump with a shut-off valve between pump and holding tank.

**Hose:** Use 1-1/2" ID [non-collapsible vacuum rated] hose on inlet [suction] side. Use stainless steel hose clamps on all sanitation connections.

**Flange:** To mount to 1-1/2" female flange, inlet barb must be cut off just before threads. Seal threads and hand tighten.

**WARNING:** Any air leak on inlet side can cause pump to run dry and can damage impeller and impeller housing. Check all inlet side connections, even those on deck plates. All runs should be smooth with no kinks or sharp angles.

**OUTLET:** Use 1" minimum ID hose on discharge side of pump. Connect to thru hull fitting above highest heeled point above waterline. Vented loop installations must vent at least 10" above highest heeled point above waterline. Use stainless steel hose clamps on all sanitation connections.



# Nuova Rade

Marine - Plastics Technology Experts

## Waste Pump With Macerator (94562 - 94563)

### Maintenance

#### TURN OFF ALL POWER!

#### Rear End Cap/ Motor Shaft Slot Access

Loosen shaft knob (15). put the D-type rotary knob mounted on one end of the rear end of the motor.

#### Pump Disassembly

- Remove 4 cover screws (1).
- Remove cutter housing (3) and gasket (4). It is necessary to hold the motor shaft steady.
- Remove hex nut (4) and cutter blades (5) & (6).
- Insert a screwdriver into slot on motor shaft (see slot access above), or slip a thin wrench (9/32" [7mm]) behind blades onto flat of motor shaft. ]
- Remove hex nut (5) and cutter blade (6).
- Remove top wear plate (7). gasket (4), impeller (8) and bottom wear plate (9).

- Remove impeller housing (10) and shaft seal (12). It is not necessary to remove slinger (13).
- Ensure the slinger (13) is on the motor shaft.
- Ensure that the shaft seal (12) can be inserted into the right position of impeller housing (10).
- Install the impeller housing (10) to the motor shaft.
- Install the bottom wear plate (9) insert to the impeller housing (10).
- Rotate the impeller (8) to the impeller housing (10) with counterclockwise.
- Install the gasket (4) and top wear plate (7).
- Install the cutter blade (6) and aligned with the motor shaft. Fixing the motor shaft with a screwdriver or a wrench (9/32 "[7mm]) to tighten the hex nut (5).
- Installed gasket (4), cutter housing (3), and tighten the screw (1).

#### Parts List

Item	Description	Qty
1	Six Angle Cover Screw	4
2	Inlet Waterproof Cap	1
3	Cutter Housing	1
4	Gasket	2
5	Hex Nut	1
6	Cutter Blade	1

Item	Description	Qty
7	Top Wear Plate	1
8	Impeller	1
9	Bottom Wear Plate	1
10	Impeller Housing	1
11	Outlet Waterproof Cap	1
12	Shaft Seal	1
13	Slinger	1
14	Motor Assembly	1
15	Shaft Knob	1
16	Baseplate Assembly	1
17	Rubber Feet	4
18	Screw	2

