



## Liferaft SOLAS OCEANO Davit-launched Self-righting Type

**SOLAS / MED APPROVED**



- For use on all types of passenger vessels, providing safe evacuation from the vessel's deck
- Equipment packs: SOLAS Pack A or SOLAS Pack B
- Available capacities: from 16 to 37 persons
- GRP canister
- Durable rubber fabric
- Double chamber tubes
- Stowage height up to 36m (Painter Line up to 46m)
- Insulated floor for low temperature conditions
- High visibility canopy with SOLAS Retroreflective Tapes
- Fully operational at temperatures from -30°C up to +65°C
- Global Service Stations' network
- Supplied with deck cradle in wooden box

LALIZAS  
OCEANO

16, 20, 25 & 37 Persons

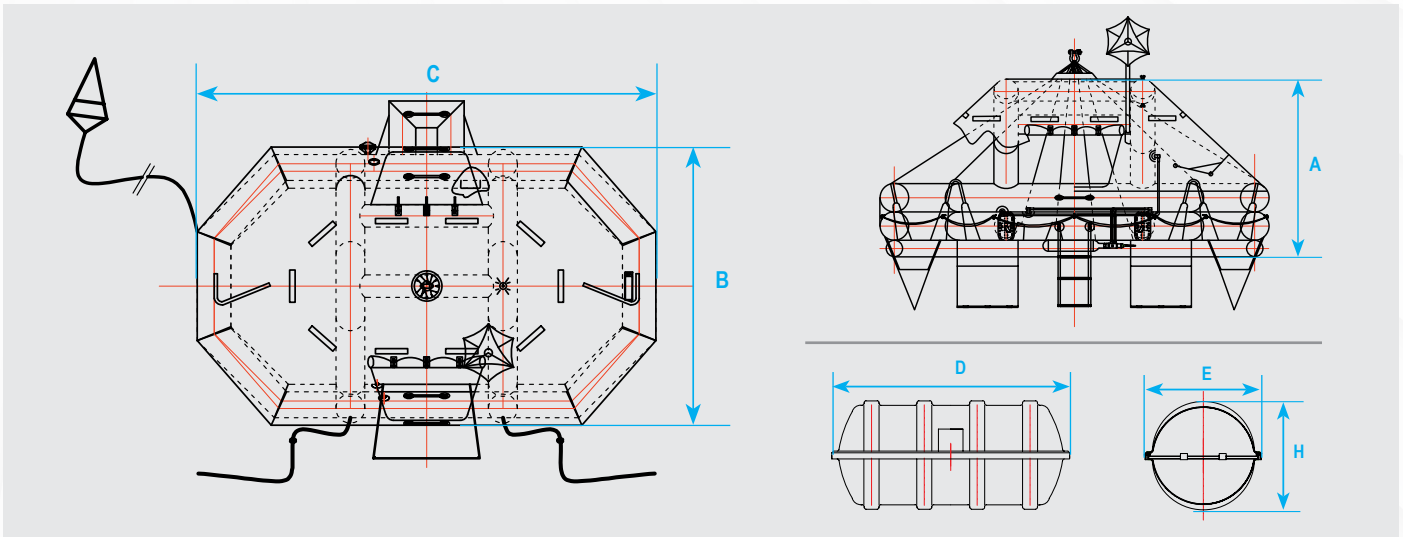

Code	Persons	Weight (kg)*	Pack	Dimensions (mm)					
				A	B	C	D	E	H
73138	16	180	A	1950	2950	4270	1470	750	710
73142		B	1350				700	660	
73139	20	215	A	2200	2860	4700	1680	770	710
73143		B	1470				750	710	
73140	25	265	A	2380	3240	5255	1660	820	715
73144		B	1470				750	710	
73141	37	370	A	2600	3780	6280	1875	850	835
73145		B	1660				820	715	

\* Total weight of each liferaft including its canister, without the deck cradle & the wooden box.