

Liferaft SOLAS OCEANO Davit-launched Type

SOLAS / MED APPROVED

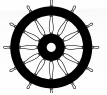

LALIZAS
OCEANO

- For use on all kinds of vessels, providing safe evacuation from the vessel's deck
- Equipment packs: SOLAS Pack A or SOLAS Pack B
- Available capacities: from 15 to 25 persons
- GRP canister
- Durable rubber fabric
- Double chambered tubes
- Stowage height up to 36m (Painter line up to 46m)
- Insulated floor for low temperature conditions
- High visibility canopy with SOLAS Retroreflective Tapes
- Fully operational at temperatures from -30°C up to +65°C
- Global Service Stations' network
- Supplied with deck cradle in wooden box

16, 20 & 25 Persons

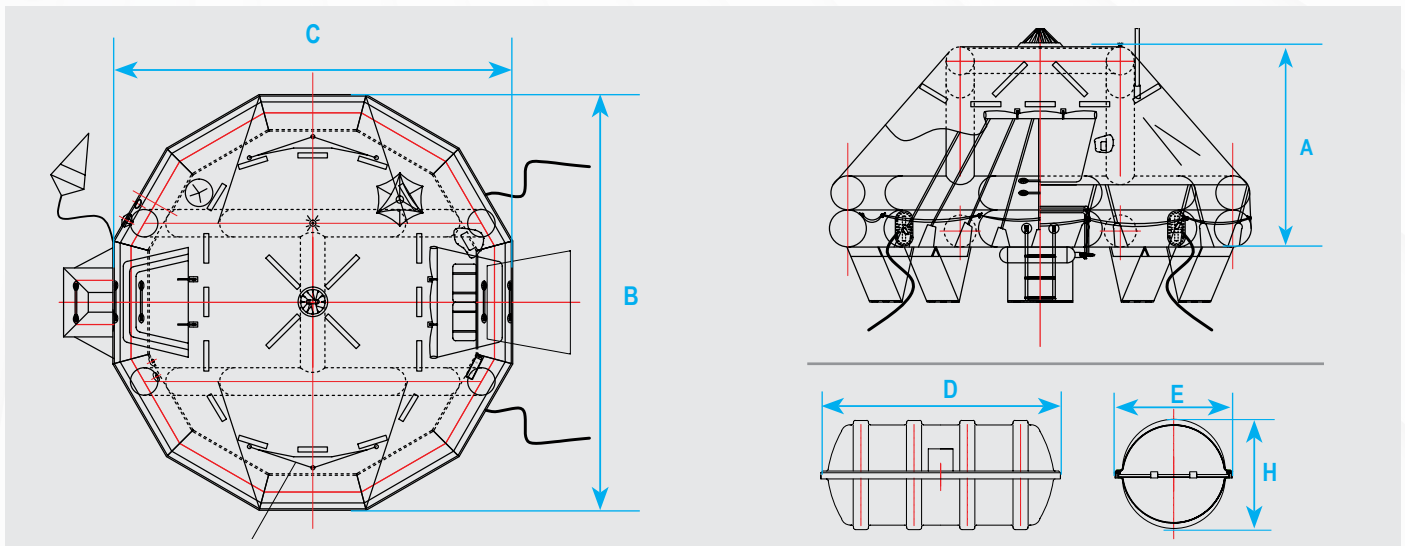

Code	Persons	Weight (kg)*	Pack	Dimensions (mm)					
				A	B	C	D	E	H
73134	16	160	A	1800	3392	3302	1350	700	700
73135		125	B				1285	670	670
79885	20	208	A	1850	3815	3715	1470	750	710
79888		165	B				1350	700	660
79886	25	240	A	2000	4225	4065	1680	770	710
79889		185	B				1470	750	710

* Total weight of each liferaft including its canister, without the deck cradle & the wooden box.